

**PARTS
COST GUIDE
£25**



- * **Breath Control for any Electronic Instrument**
- * **State Variable Filter**
- * **Voltage Controlled Amplifier**
- * **External Control and Trigger Outputs**
- * **Provides Dynamic Expression**
- * **Battery Operation**

E&MM Synblo



by Kenneth McAlpine

There are many ways of adding expression to your playing; using footpedals, effectors, modulation controls or by altering control settings. The number of parameters you can alter at once, however, is dictated by how many spare hands/feet you have at your disposal!

The Synblo has been designed to add dynamic expression to an instrument signal using only the player's breath. By blowing into the plastic pipe connected to the unit you can control Harmonic content and Amplitude, with the internal Filter and Amplifier, or another variable parameter connected to the external output. A trigger signal is also available which is activated when the 'breath' signal reaches a pre-set threshold.

A block diagram of the system is shown in Figure 1. The Breath input consists of a crystal microphone insert mounted directly onto the PCB. Air blown along the plastic tube, connected to the unit via a modified 1/4" jack plug (see construction text), then passes into the mic producing a signal. This signal is amplified, rectified and smoothed by the envelope follower and then buffered to provide the control voltage.

The Sensitivity control adjusts the mic level and therefore how hard you have to blow to operate the circuit, while Decay adjusts the decay time of the envelope follower/generator. This control voltage is fed to the Voltage Controlled Filter (VCF), the Voltage Controlled Amplifier (VCA), to the trigger circuit and to the external output. An LED is also connected to this point to provide an indication of the CV level.

The instrument signal is first passed through the VCF which is a -12dB/Octave State Variable filter which can be switched between Band and Low pass modes. The Resonance control alters the feedback or 'Q' of the filter while the Level control sets the manual cut-off frequency. The output of the filter then goes into the VCA which also has a Level control to set the manual gain. Both the VCF and VCA have 'Bend' controls which adjust the amount of control voltage from the

'Breath' section. The output from the amplifier is connected to a Bypass switch which can be used to switch the unit in or out.

Circuit

The full circuit diagram of the Synblo is given in Figure 2.

The crystal mic insert is connected directly to the Sensitivity control. The signal tapped from the pot is filtered, to cut off low frequency 'thumps', by C1 and R1 and then amplified and rectified by IC1a, the gain of which is set up by R3 and R2. The output from the op-amp is used to charge up C2 and produce the required envelope. A discharge path is created by R4 and the control RV2 which sets their decay rate. A final low pass filter is provided by R5 and C3 to clean up

any noise on the control voltage. The signal is buffered by IC1b and then sent to the 3 pots for Filter, Amplifier and External Bend, the LED and the comparator IC1c. The threshold for this device is approx 1V and is set up by the potential divider R7 and R8.

Both the VCF and VCA require positive and negative supplies, which are created by producing a third centre rail which is used as '0V'. The centre rail, is produced by potential divider R32 and R33 and buffered by IC1d.

The VCF is built around one IC, that is the LM13600, this device contains two trans-conductance amplifiers and two matching buffers. In the configuration shown IC2 acts as a State Variable filter with a roll-off of -12dB/Octave.

The input impedance is 47k and signals up to 1.5V P-P can be handled before distortion. The input signal is decoupled by C4 and attenuated to a suitable level for IC2a by R11 and R12. The output signal can be taken from either pin 8 or 9 giving bandpass or lowpass characteristics respectively.

The cut-off frequency of the filter is set by the current flowing into pins 1 and 16 and therefore by the voltage applied to R19 and R20. The manual cut-off frequency is set by RV7 and the 'Bend' amount by RV3.

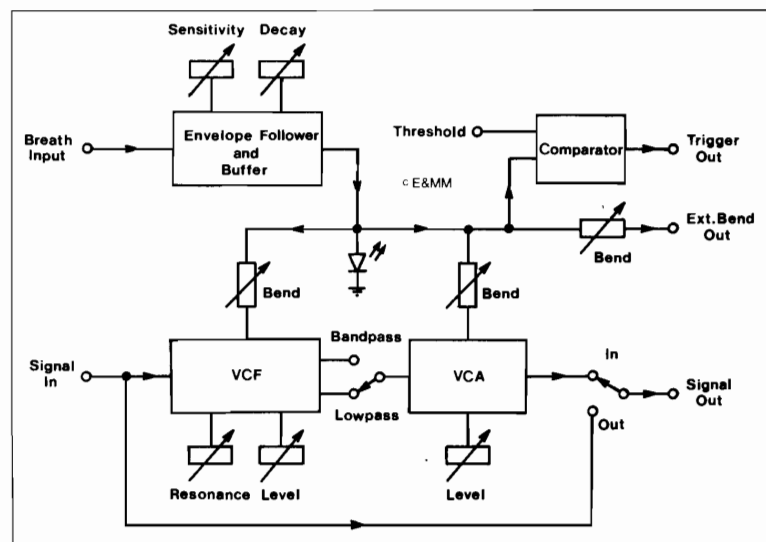

Figure 1. Block diagram of the Synblo.

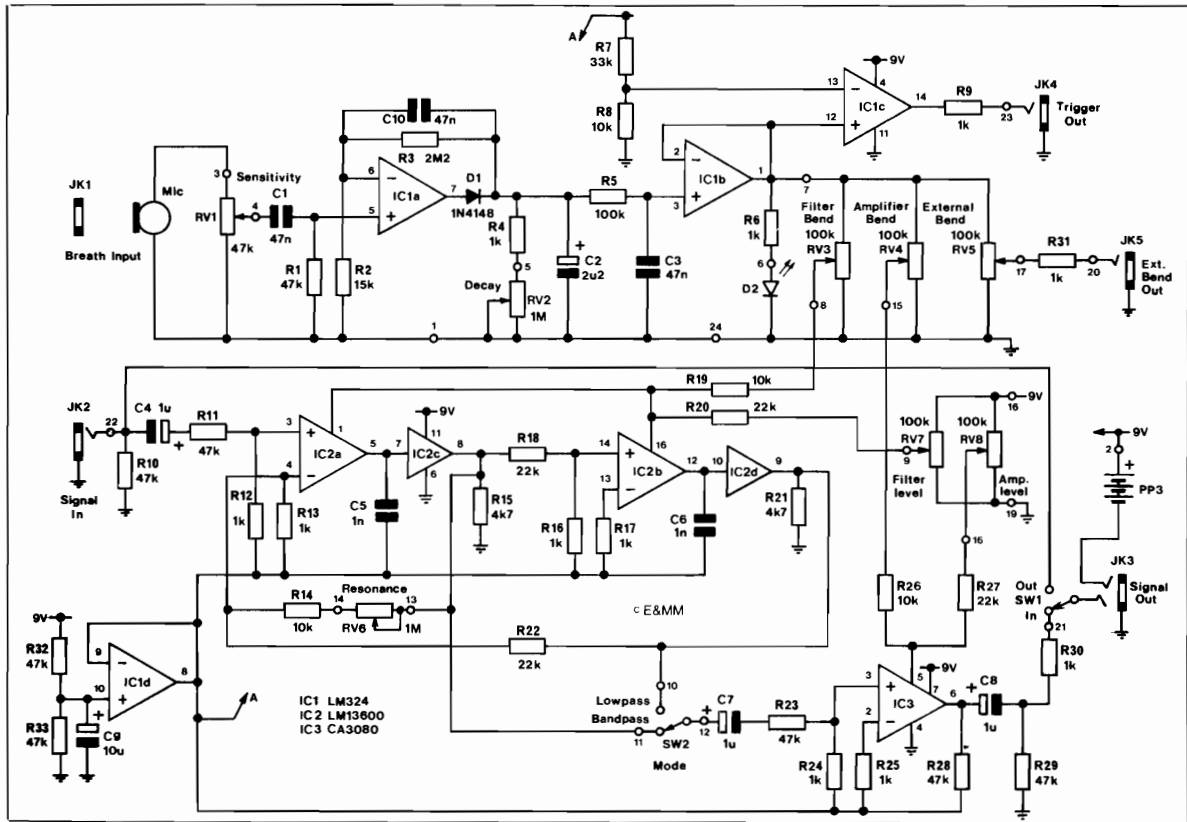

Figure 2. Circuit diagram of the Synblo.

The output from the filter is applied to the VCA via the capacitor C7 and is attenuated by R23 and 24. The VCA is based around the CA3080 transconductance amplifier. The gain of this device is set by the current flowing into pin 5 and therefore by the voltage applied to R26 and 27. The manual gain is set by RV8 and the 'Bend' amount by RV4. The output current is converted to a voltage across load resistor R28. This voltage is decoupled by C8 and fed to the bypass switch SW1. The 'Signal Out' jack is a stereo type to allow the battery to be disconnected when the jack plug is removed.

Construction

The breath input on the prototype is a plastic tube connected to the case via a modified jack plug and socket. However, should you want to take the mic out of the case and use an alternative such as the boom mic on a set of headphones, a standard socket could be used to connect it to the circuitry.

The breath tube was constructed using plastic tubing with a 3/16" internal diameter and a standard 1/4" plastic jack plug (with metal collar). The plug is converted by removing the tip, insulation, connecting stem, which runs up the middle of the jack, and the solder tags. This is accomplished by removing the casing and cutting the pressed end of the stem with a large pair of cutters. The jack plug should now fall apart leaving you with the outer tubing (earth) and threaded collar intact. The plastic tubing should be a good tight fit into the plastic jack body and once secured (with an epoxy if required) can be screwed onto the modified metal part. The edge of the metal tubing should be rounded off with a small file to make insertion into the socket easier, since the tapered tip has now been removed.

The receiving socket is a moulded plastic

Continued on page 66.

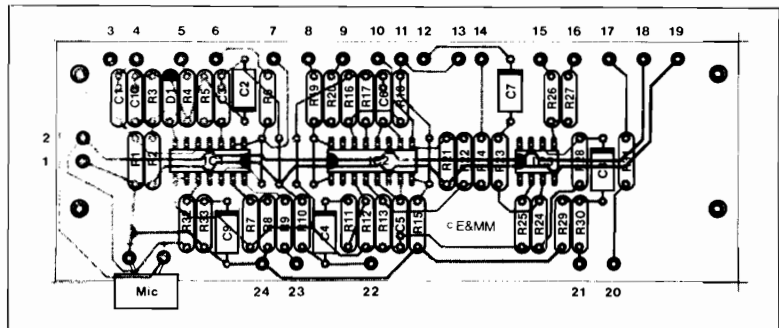
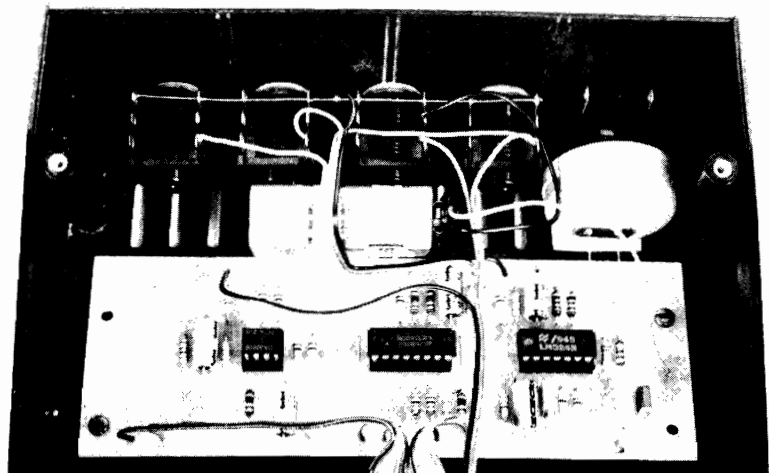

Figure 3. Component overlay of the Synblo PCB.



An internal view of the Synblo.

E&MM Synblo

type. Since the jack plug now has no 'live' connection half of the socket has to be removed. This can be done using a sharp knife or small hacksaw. This leaves only the 'earth' contact which, being sprung, holds the breath pipe plug.

A finished case can be supplied by E&MM. The only modification required is to cut a hole in the bottom of the box to allow excess moisture from the tube to drip out. The size of the hole depends on the dimensions of the mic used. (A sharp modelling knife makes quick work of this stage.)

All the components are mounted on the PCB with the pots and sockets connected with flying leads.

With Figure 3 as a guide insert and solder the links (5 in all), then the resistors, diode, capacitors — making sure that the electrolytics are inserted the right way round, and finally the IC sockets, if required. The IC's can be inserted at this stage — again noting the correct orientation.

Presuming that the E&MM case is used, or that you have prepared a suitable enclosure, the wiring can now commence.

First the control panel: once the pots and switches have been mounted the common connections can be made. Using solid core wire link between the right hand tags of pots RV1-5, 7, 8 and the LED. Then connections between the left hand tags of pots RV3, 4, 5 and between the left hand tags of pots RV7, 8 can be made. The rest of the wiring is to the PCB and is made with reference to the wiring table and Figure 3.

Next the rear panel: Connect a common 'earth' bar between the sockets and then refer to the wiring table and Figure 3 for the PCB connections.

Lastly, the mic insert can be connected/ mounted to the board using stiff single core wire spaced approximately 1/2" from the edge (see internal photographs). Foam padding can be inserted to prevent it moving around if the case is likely to receive any violent knocks.

Testing

Since there are no presets to adjust, testing is a simple matter of connecting an output (to switch on the unit), the breath pipe and a battery.

With the Sensitivity and Decay controls halfway blow into the pipe, the LED should glow brightly then gradually fade. If this does not occur check all connections and com-

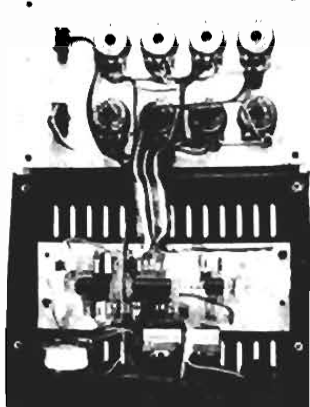

An internal view of PCB and Control Panel Wiring.



The Synblo in use.

WIRING TABLE

FROM	TO		
1	Spare Ground	14	RV6/3
2	+ve battery	15	RV4/2
3	RV1/1	16	RV8/2
4	RV1/2	17	RV5/2
5	RV2/2	18	RV7, 8/1
6	D2 Anode	19	RV1-5, 7, 8/3
7	RV3-5/1	20	JK5/2
8	RV3/2	21	SW1/1
9	RV7/2	22	JK2/2, SW1/3
10	SW2/1	23	JK4/2
11	SW2/3	24	RV1-5/3
12	SW2/2	SW1/2	JK3/3
13	RV6/2	JK3/2	-ve battery

ponent orientations. Presuming that all is well, connect a signal to the input, set the Amplifier Level to full and slowly increase the Filter level, the characteristic synthesiser WAA should be heard on both Lowpass and Bandpass settings. Now turn up the 'Bend' controls and check that the breath input modifies both the Filter and the Amplifier.

When both the External output and the Trigger have been tested, and are known to be working, the unit can be used to make music!

Using the Synblo

The only way to get the best results out of the Synblo is to experiment and practise, however, a good initial setting is: Sensitivity — 7, Amplifier Bend — 8, Amplifier Level — 5, Decay — 4, Filter Bend — 8, Filter Level — 4, Resonance — 10.

Points to note when using the Synblo: 1) Since a fair amount of liquid drips from the casing, especially with enthusiastic playing, it should be situated away from vulnerable electronic equipment. A piece of blotting paper or similar material under the case can prevent any problems. 2) If the internal mic is used the case should not be placed on or near speakers which are relaying the processed signal otherwise feedback can occur holding the envelope on

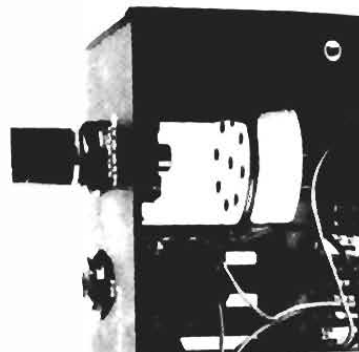

The breath input plug and socket.

PARTS LIST FOR SYNBLO

Resistors — all 1/4W, 5%, carbon film

R1,10,11,23,28,29,32,33	47k
R2	15k
R3	2M2
R4,6,9,12,13,16,17,24,25,30,31	1k
R5	100k
R7	33k
R8,14,19,26	10k
R15,21	4k7
R18,20,22,27	22k
RV1	47k lin
RV2,6	1M lin
RV3,4,5,7,8	100k lin

Capacitors

C1,3,10	47nF polycarbonate
C2	2u2 63V Axial Electrolytic
C4,7,8	1uF 63V Axial Electrolytic
C5,6	1nF ceramic
C9	10uF 25V Axial Electrolytic

Semiconductors

D1	1N4148
D2	0.2" LED
IC1	3403 or LM324
IC2	LM13600
IC3	CA3080

Miscellaneous

JK1,2,4,5	1/4" Mono jack socket
JK3	1/4" Stereo jack socket
SW1,2	SPDT miniature switch
MIC	Crystal Mic Insert
	8 pin DIL socket
	14 pin DIL socket
	16 pin DIL socket
	LED clip
	Knobs and caps
	Battery connector
	PCB
	Case
	Connecting wire
	1M 3/16" dia. Plastic Tubing
	1/4" Mono jack plug

thereby losing the effect of the breath pipe.

The external control can be used with another synthesiser to great effect to bend oscillator frequency, pulse width, modulation depth etc., if these parameters are accessible on the instrument. The trigger can also be used to provide some interesting effects. It provides a positive going +9V signal which stays high for the duration of the breath input or Decay envelope. This can be used to trigger ADSR's or even to clock a sequencer! The possibilities are endless, so put your music where your mouth is!

E&MM

A fully finished case for Synblo with drilled, silk screened, panel is available from E&MM, 282 London Road, Westcliff-on-Sea, Essex SS0 7JG at £7.95 inc VAT and P&P. Please order as: Synblo case.
The PCB for Synblo is also available from the above address at £2.45 inc VAT and P&P. Please order as: Synblo PCB.