

# MODULE 80-2 VOLTAGE CONTROLLED OSCILLATOR

## 1. INTRODUCTION

The DIGISOUND 80-2 voltage controlled oscillator (VCO) has a 1V/octave response with a high level of stability and accuracy in the frequency range of 5Hz to 10kHz. The quality of the VCO is such that the modules may be used in polyphonic systems, such as, the ALPHADAC 16 microprocessor controller. The full frequency range is approximately 0.1Hz to 50kHz.

The design is based on the CEM 3340 IC from Curtis Electromusic Specialties. The latter provides triangle, sawtooth

and pulse waveforms and in the 80-2 a sine wave is derived from the triangle output. These four waveforms are 0 to +10V in amplitude. Additionally the sine and triangle are available as +/-5V outputs. The duty cycle of the pulse waveform may be varied from 0 to 100%, either manually or by an external control voltage thus allowing pulse width modulation techniques. In addition to frequency modulation via the exponential control input(s) a linear frequency modulation input is included which produces a 10% change in frequency per volt.

The CEM 3340 has three methods for synchronising the VCO to other oscillators of the same type and these methods have been incorporated in the design to provide an exceptional range of modulation and harmonic locking effects.

## 2. DESIGN

The complete circuit diagram for the 80-2 VCO is shown in Figure 2. Most of the circuit is centred around IC1, the CEM 3340, whose pin out and functional block diagram is shown in Figure 3. The frequency control input, pin 15, is a summing stage while pin 14 provides the scaling factor. Since the current gain of the internal multiplier is set near unity 100k input resistors (R5, R6) and a 1k8 scaling resistor (R3) produce the standard 1V/octave response and about 18mV at the base of Q1. Note that R6 has an attenuator, RV9, attached and this input will normally be used for frequency modulation. The input to R5 on the other hand will invariably be connected to the keyboard control voltage and the VCO is calibrated through this input to achieve the accuracy necessary when operated from the keyboard. Components R4 and RV2 set the initial frequency of the oscillator and have been chosen such that with no external voltage applied the frequency may be adjusted to 65.406Hz, i.e., the lowest note of a four octave C-C keyboard. R7 and RV7 allow manual adjustment of the VCO by +/-5octaves. Switch S1 has been

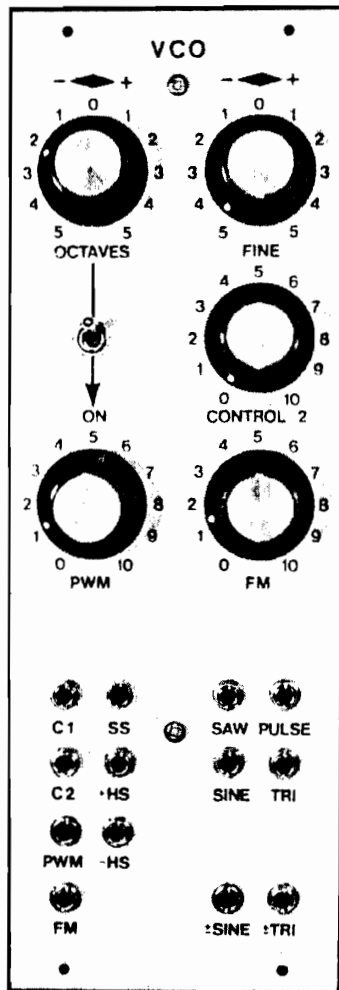

FIGURE 1. 80-2 PANEL

fitted between RV7 and R7 so that in normal use, i.e., keyboard; precise octave shift; and external voltage controls, slight variation in RV7 will not cause the oscillator to go out of tune. R8 and RV8 provide a fine adjustment of approximately +/-0.5 octaves and is essentially for tuning purposes. The other components (R9, C5) on the summing input are for compensation and are always required. The sum of the input voltages to pin 15 should always remain positive for proper operation of the oscillator.

For greatest accuracy of the internal multiplier the current flowing out of pin 2 should be close to the current flowing out of pin 1 and this balance is achieved with RV1.

The exponential generator in the CEM 3340 is capable of delivering a current, for charging and discharging the timing capacitor, C7, from greater than 500uA to less than the input bias current of the buffer which gives a typical frequency range of 500,000:1. For synthesiser applications, however, one should use the most accurate portion of this range, which is from 50nA to 100uA. Thus with a lnF timing capacitor and a positive supply

voltage of +15V the most accurate range will be from 5Hz to 10kHz.

As is normal with exponential generators a reference current needs to be established and for the CEM 3340 this is 10uA which is derived from R11 connected to the positive supply. This input, pin 13, may also be used for linear frequency modulation of the VCO. R12 adjusts the FM range to a 10% change in frequency per volt and an attenuating potentiometer, RV10, allows manual adjustment of this range. The FM input has been AC coupled so as to avoid errors from any DC offset on driving inputs. It may, however, be DC coupled so long as the user is aware that any DC offsets will cause the oscillator to go out of tune. Furthermore, a negative current at pin 13 in excess of the reference current will gate the oscillator off. A stable reference current is essential to maintain the accuracy of the oscillator and thus a stable power supply must be used.

One of the biggest drawbacks to exponential VCO's has been their temperature sensitivity which resulted in frequency drift as they warmed up. One of the novel features of the CEM

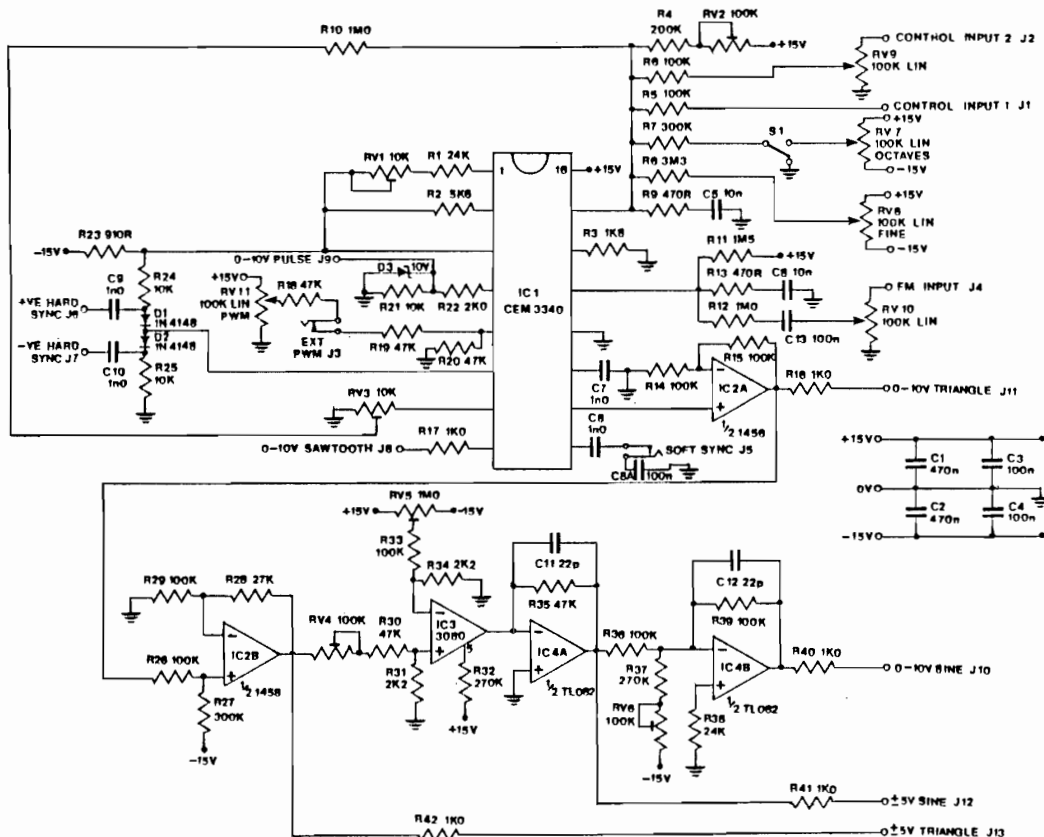

FIGURE 2. CIRCUIT FOR 80-2 VCO

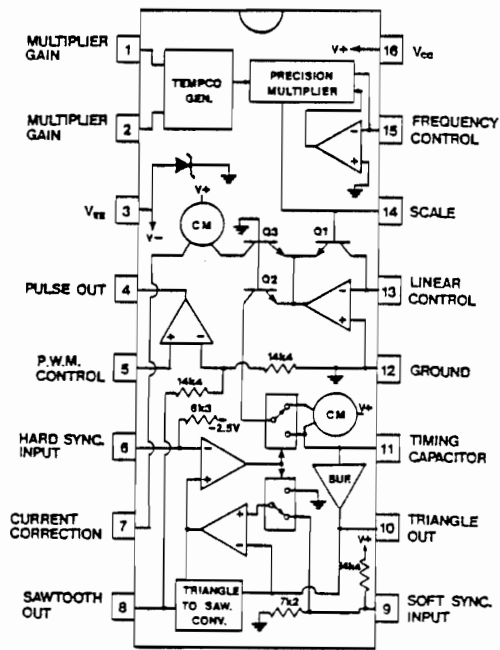

FIGURE 3. CEM 3340 IC

3340 is the incorporation of temperature compensation. This is achieved by multiplying the current sourced into the control pin (pin 15) by a coefficient directly proportional to the absolute temperature. This coefficient is produced by the 'Tempco Generator' using the same mechanism as in the exponential generator and thus cancellation is nearly perfect.

A further problem with transistor based exponential generators is that their bulk emitter resistance becomes significant as current is increased and this in turn will cause the oscillator to go flat. With the CEM 3340 this situation applies when current from Q2 (see Figure 3) is greater than 50uA. Means of correcting this source of error have been included since pin 7 outputs a current which is a quarter of the exponential generator current. The current is converted into a voltage across RV3 and a proportion fed back into the control input via R10.

All waveform outputs from the IC are short circuit protected and may be shorted continuously without damaging the device. A 0-10V sawtooth waveform is available at pin 8 which can sink at least 0.6mA and source over several milliamps without any effect on oscillator performance and only a negligible effect on waveshape. The pulse output from pin 4 is an open NPN emitter and therefore requires a pull

down resistor to ground or a negative voltage. This output has been clamped with a 10V zener diode, D3, to give a 0-10V pulse output. Pin 5 allows pulse width modulation and 0 to +5V applied to this pin will vary the pulse width from 0 to 100%. Attenuating resistors R19 and R20 increase the control range to +10V, which is the standard adopted for the DIGISOUND 80 series of modules. RV11 connected to +15V provides manual control of pulse width and this control voltage is reduced by R18 such that the effective control voltage from RV11 is +10V. RV11 is connected to a jack socket, J3, such that it is disabled when an external control voltage is being applied. Note that 0 to 100% pulse width modulation results in the pulse 'disappearing' at the extremes of the potentiometer or external control voltage. Pin 10 outputs a 0-5V triangle waveform. Although the sink and source capabilities approach those of the sawtooth this triangle output has a finite impedance and also drives the comparator with the result that loading into even a 100k input may lower frequency by 0.15%, in the worst case. This output has therefore been buffered by IC2a and addition of R14 and R15 increases the gain by two to provide a 0-10V output.

The triangle output is converted to +/-5V at IC2b (this output is also made available from the VCO) and attenuated to about +/-100mV by RV4, R30 and R31 prior to IC3 which is a CA 3080E, or equivalent. At high input levels this OTA becomes non linear in response and use is made of this to convert the triangle waveform into a sine wave. RV4 adjusts the third harmonic content while RV5 and associated components at the inverting input of IC3 trim the second harmonic. IC4a converts the current from IC3 to a voltage and provides a +/-5V sine wave. This output is inverted compared to all other outputs but this is not detrimental for normal use. It should be noted, however, that mixing of this waveform with other outputs will have a subtracting effect. Finally the +/- sine output is shifted to a 0-10V output by IC4b with R37 and RV6 used for level shifting.

The CEM 3340 will operate from a wide range of power supplies but +/-15V is the standard adopted for the 80 series. For negative supplies greater

than -7V5 a current limiting resistor must be employed at the negative supply input, pin 3. For -15V a 910R resistor, R23, is required.

Synchronisation of oscillators is often used to prevent unpleasant beating effects when two, or more, VCO's are set to ratios to produce a complex waveform. Synchronisation may, however, be used to produce some pleasing timbral effects. The CEM 3340 has a wider range of synchronising effects than found on conventional synchronised oscillators. Soft synchronisation by negative pulses to pin 9 causes the triangle upper peak to reverse direction prematurely with the result that the oscillation period is an integral multiple of the pulse period. If this input is not in use it should be by-passed to ground with a 100nF capacitor, C8A, so as to prevent unwanted synchronisation or waveform instability from noise pulses on the positive supply line. Pin 6 is

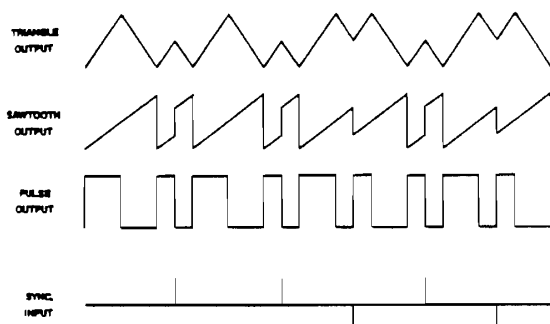

FIGURE 4. HARD SYNCHRONISATION

used for hard synchronisation and R24, D1 and C9 allow synchronisation from rising edges while R25, D2 and C10 allow synchronisation from falling edges. A positive sync. pulse will cause the triangle wave to reverse direction only during the rising portion of the triangle, whereas a negative sync. pulse will cause direction reversal only during the falling portion. Figure 4 illustrates the hard synchronisation capabilities of the CEM 3340 and as employed in the 80-2 module.

Reference should be made to the CEM 3340 data sheet for further information regarding component selection for other frequency ranges, alternative power supplies and so on. As regards utilising the synchronisation and other capabilities of the VCO then reference should be made to 'USING THE DIGISOUND 80 MODULAR SYNTHESISER'.

### 3. CONSTRUCTION

The 80-2 PCB is printed with a component overlay which simplifies the construction stage. The overlay is reproduced in Figure 5 to allow checking of component placement after the module has been constructed.

Take special care regarding orientation of the IC's. Even after installing the DIL sockets the number '1', denoting pin 1, will still be visible on the PCB. In any event compare the completed PCB against Figure 5 before applying power. For the diodes a line is printed on the PCB, either above or below the 'D' number and this line corresponds with the band on the diode denoting the cathode.

Wiring of potentiometers and other panel connections to the PCB are shown in Figure 6. This diagram illustrates the components when viewed from the rear of the panel. The arrows and associated letters indicate that a wire connection must be made from the position shown to the PCB. The latter has a connecting point on its front edge with letters corresponding to those shown in Figure 6. DO NOT MAKE THE CONNECTION BETWEEN THE FINE CONTROL POTENTIOMETER, RV8, AND THE PCB AT THIS STAGE. Note the location of C8A on the soft synchronisation jack socket. Unlike most other DIGISOUND 80 modules it will be found most convenient to mount the PCB in such a way that the power connecting point is at the top of the panel. This reduces the length of most wires and also gives ready access to the frequency trimmers by simply tilting the panel forward from its housing.

The jack sockets in the diagram are of the type supplied by Digisound Limited. The top connection, as illustrated, is the connection which is made with the jack when the latter is inserted. The lower connection is disabled by insertion of a jack plug. Finally, the tab under the socket is the ground connection. It is recommended that all of these ground connections are wired to the 0V line since this facilitates connection of the VCO to other equipment which may be using a separate power supply. The ground tabs may be joined together using tinned copper wire but other panel wiring should be made with

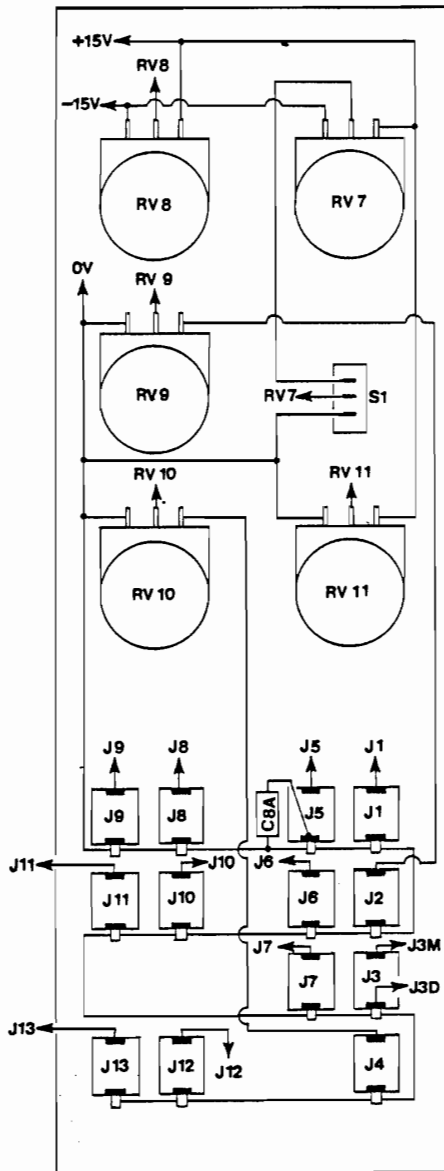

FIGURE 6. PANEL WIRING

insulated wire. 1/0.6mm insulated wire is ideal for panel wiring since it retains any shaping and thus allows a neat appearance to be obtained. Wires should be kept as short as practical.

One special point to note is that cleanliness of the PCB is particularly important in the area around the timing capacitor, C7. At low frequencies the current to this capacitor is only a few nanoamps and so residual solder flux or other dirt around the capacitor may degrade performance. Use either a proprietary PCB solvent cleaner or else carefully scrape clean the foil side of the PCB around the solder points for C7.

On completion of the construction stage carefully examine the underside of the PCB to ensure that all components and connections are properly soldered and that no solder bridges have been formed. Also check polarity of power supplies and that a good ground (0V) connection is present before applying the power to the module. For example, if the recommended CHIRI connector is being used then check voltage at its pins using 0V as the ground for the meter. Do not have the power turned on when the connector is mated with the CHIRI plug on the PCB. A further precaution is to have the VCO connected to an oscilloscope or an amplifier when it is powered for the first time. For the latter connect the +10V triangle to an amplifier, with its 'volume' control nearly off, and apply power to the module. If there is no response

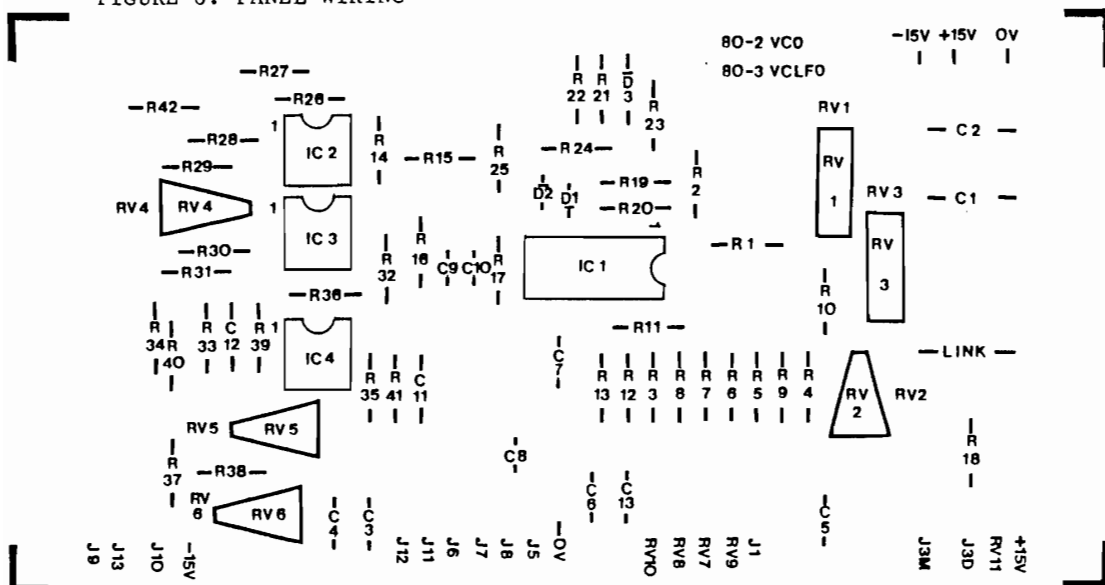

FIGURE 5. COMPONENT OVERLAY FOR 80-2

then switch off immediately and repeat all of the checks mentioned above. If functioning then check the other waveform outputs although remember that the sinewave has not been trimmed at this time.

After constructing the module you will be anxious to try it out. Do not, however, skip the tedious checking procedure since mistakes can be expensive.

## 4. CALIBRATION

The first step is to adjust the sinewave outputs and trimmers RV4 to RV6 should be set to their mid position. With an oscilloscope, or by ear via an amplifier, adjust RV4 then RV5 for purest sinewave output. These adjustments may have to be repeated a few times to obtain the best result. Next adjust RV6 to get the +10V sine output referenced to ground. The simplest method is with a DC coupled oscilloscope and RV6 is adjusted such that the bottom of the sinewave is at 0V. An alternative method is to use a voltage controlled amplifier (VCA), such as the DIGISOUND 80-9. Connect a signal to the VCA and insert a jack plug into the exponential control input and while listening to the output, using an audio amplifier, adjust signal level or amplifier volume such that no sound is heard. Now connect the +10V sinewave to the VCA and adjust RV6 until no sound is heard. For the latter step the VCO should be set to its lowest frequency, that is, S1 to the 'ON' position and RV7 fully anti-clockwise. If a VCA is not available at this stage then this step may be left until such times as suitable equipment is available. One should remember, however, that it is not trimmed if it is used in a patch.

The last and most important step is to calibrate the oscillator to the 1V/octave relationship. Before starting first check the voltage from the power supplies and trim to +/-15V, if necessary. Calibration is greatly simplified if one has available: a variable voltage source (from a potentiometer or from a calibrated keyboard); an accurate voltmeter; and a digital frequency meter. There are, however, a number of other methods. One is to use a previously calibrated oscillator or a musical instrument and

make the calibration using the beat frequency technique. Another approach is to build two simple, but stable, fixed frequency oscillators and use them in conjunction with an oscilloscope to calibrate the VCO by generating Lissajous figures.

Whichever method is used the calibration procedure is as follows. Set the wiper of RV3 at the grounded end by turning the adjusting screw clockwise until clicks are heard (or seen if a multiturn with a transparent cover is supplied) and the wiper of RV1 to about mid position. Put switch, S1, to the 'OFF' position so as to disable the 'octaves' control, RV7. Next apply a positive voltage to Control Input 1 (R5) until the frequency is about 200Hz. Increase voltage by exactly one volt (as accurately as the measuring equipment allows) and adjust RV1 until the frequency is double that of the first frequency. These steps may have to be repeated several times in order to achieve an exact doubling of frequency per volt applied. If using a digital frequency meter then the best approach is to note the first measurement, increase voltage by one volt and divide the second reading by the first. If the ratio is greater than 2 then turn RV1 anti-clockwise and if less than 2 then turn it clockwise. Now decrease the voltage by exactly one volt and calculate the new ratio and adjust RV1 as before. Continue the procedure until a ratio of exactly 2 is obtained and during the calibration it may be necessary to alter the voltage level such that the calibration is carried out in the general range of 150 to 500Hz.

Repeat the above procedure except for starting at an initial frequency of about 5kHz and adjusting RV3 until a doubling of this frequency is obtained when the applied voltage is increased by exactly one volt. Note that this is a fine adjustment and if the low frequency calibration has not been carried out accurately then it may be found impossible to carry out this step effectively. If accurate calibration is not possible at this stage then set the wiper of RV3 to its mid position. If the high frequency trim has been carried out then recheck the low frequency calibration and the performance of the VCO over its specified range.

Two important things to note are: (a) That the VCO has been calibrated for Control Input 1 which will normally be connected to the keyboard. It may not be in exact calibration for Control Input 2 due to small variations in components; (b) Resistors and other components will age and their change may be quite significant for a period following soldering. If convenient the best approach is to make a quick initial calibration and then a more accurate one after using, or keeping the module powered up, for several hours.

The oscillator may now be adjusted so that with no input voltages it will be tuned to the lowest frequency of a four octave C-C keyboard. Adjust RV2 to 65.4Hz if connected to a keyboard with zero volts at lowest key. This step is not essential until the VCO is connected to a keyboard. The value of RV2 or R4 may be altered to suit other keyboard requirements.

Finally, the wire to the wiper of the fine control potentiometer, RV8, may be connected up and this may also be used to tune to particular keyboard requirements or to other instruments.

## 5. COMPONENTS

### RESISTORS, 5%, 1/4w carbon film

R8	3M3
R9,13	470R
R12	1M0
R14,15,26,29,33,36,39	100k
R16,17,40,41,42	1k0
R18,19,20,30,35	47k
R21,24,25	10k
R22	2k0
R23	910R
R27	300k
R28	27k
R31,34	2k2
R32,37	270k
R38	24k

### RESISTORS, 1%, 1/4w metal film, 100ppm

R1	24k
R2	5k6
R3	1k8
R4	200k
R5,6	100k
R7	300k
R10	1M0
R11*	1M5

\*may be replaced by low TC carbon film resistor.

### CAPACITORS

C1,2	470n polyester
C3,4,13	100n polyester
C5,6	10n polyester
C7	1n0 polystyrene
C8,9,10	1n0 polyester
C8A (see text)	100n polyester
C11,12	22p polystyrene

### POTENTIOMETERS, PRESETS

RV1,3	10k cermet multiturn
RV2	100k cermet
RV4,6	100k carbon
RV5	1M0 carbon
RV7,8,9,10,11	100k lin.

### SEMICONDUCTORS

IC1	CEM 3340
IC2	LM 1458*
IC3	CA 3080E*
IC4	TL 082
D1,2	1N4148
D3	BZY88 10V

\*or equivalent

### MISCELLANEOUS

S1	SPDT sub. min. switch
----	-----------------------

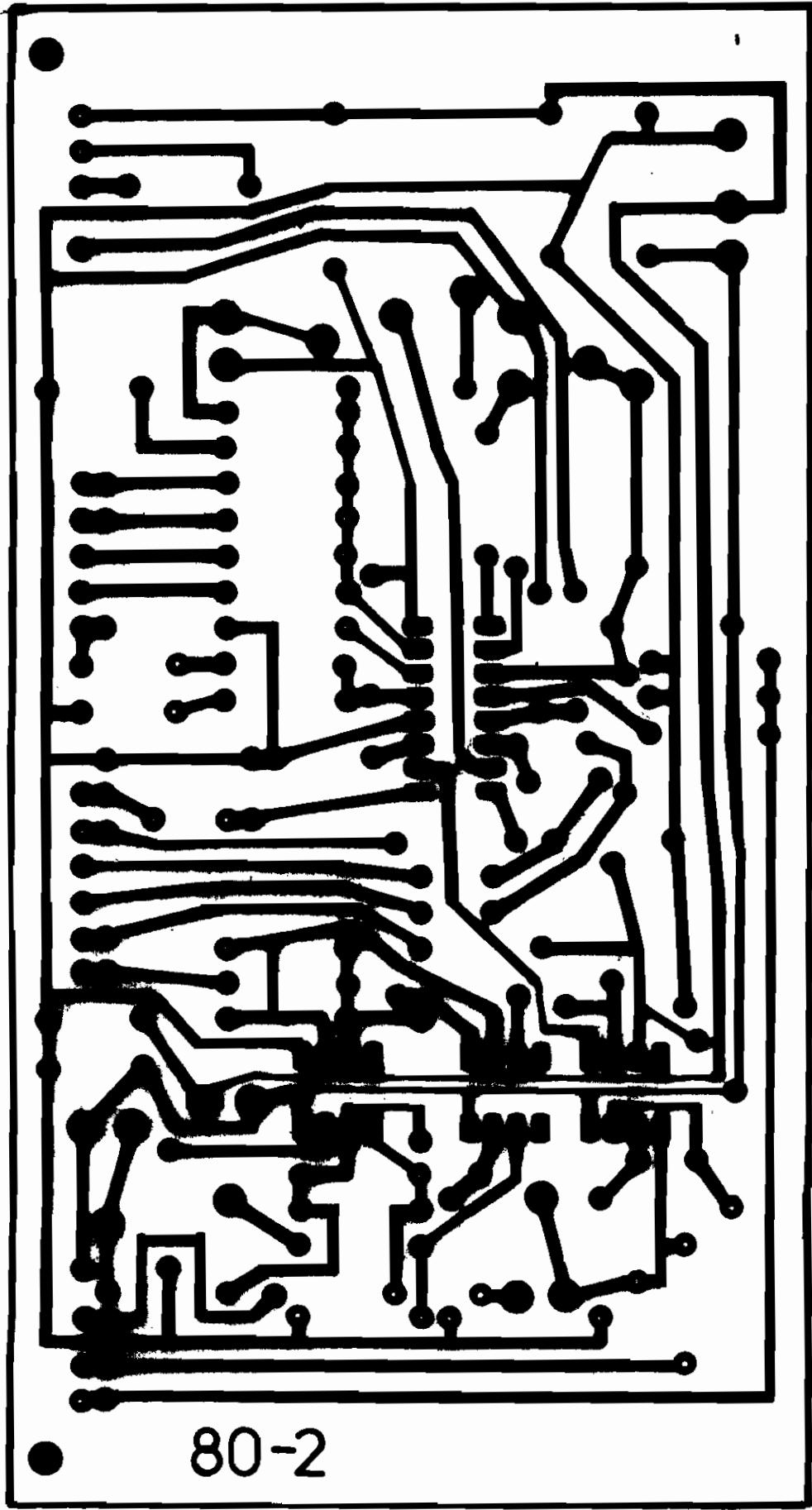

80-2